



INSTRUCTION MANUAL

**LIFTING MOTOR FOR AIR INLETS
WITH BUILT-IN BATTERIES
900KG 24V
1 SHAFT FOR TUBES**



Contenido

DESCRIPTION	3
Technical data. Motor 900kg 24V 1 shaft for tubes	3
Equipment components	3
INSTALLATION	4
Where to install the motor	4
How to fix the motor to the surface	4
Distance between the fixing holes	4
How to adjust the lifting system with tubes	5
Installation scheme with the air inlets	5
Recommendations for tube system installation	6
Dimensions of the motor shaft	6
Distance between the support brackets and the tube joining	6
Recommendations for towlines	7
Suitable towline type	7
Towline maintenance	7
CONNECTION	8
How to connect the motor to the regulator	8
Versions of the Manual Control Circuits in the motor	8
IMPORTANT	8
Cable specifications	9
How to prolong the connecting cables	9
Safety warnings for cables	9
BEFORE PROGRAMMING	10
Remember to connect the Motor-Battery connector	10
SAFETY MEASURES IN CASE OF FAULTS	11
How to use the Manual Control Circuit inside the motor	11
Mechanical limit switch	12
BUILT-IN BATTERIES	13
Specifications	13
Maintenance	14
How to check the motor's batteries	14
Correct battery maintenance in facilities WITH 230V	15
How to disconnect the batteries from the motor	15

DESCRIPTION

It is an electronic lifting motor - gearmotor - powered by high quality microcontrollers with 2 built-in 12V batteries designed to create a control system for natural or mechanical ventilation through opening or closing of the air inlets together with **OSMO** regulators: electronic, digital and compatible.

Motor movement is based on programmed steps which allow more precise temperature control.

Protected from outdoor conditions by its chassis (galvanized and painted) and its cover (stainless steel and painted) to avoid any kind of manipulation that could damage its components.

The built-in batteries provide opening and closing operation of the air inlets in facilities without 230V electric grid or for up to 24 hours during blackouts.

Technical data. Motor 900kg 24V 1 shaft for tubes



Lifting system:	1 SHAFT FOR TUBES 3/4" (adaptable for other diameter)
Motor	24V / 2Ah
2 built-in batteries	2 x 12V / 5 Ah
Safety	Internal manual control, electronic and mechanical limit switches
Speed	1RPM / linear 8cm without weight
Dimensions length/width/height	425x244x187mm
Distance shaft-base	70mm
Weight	17kg
Maximum output consumption UP/DOWN:	2Ah/ 0,35Ah

Equipment components

- Chassis: galvanized and painted
 - Cover: stainless steel and painted
 - 1 shaft: towline not included. [See: Recommendations for towline. Page 6](#)
 - Tubular motor
 - Manual control circuit with:
 - 1 male connector and 1 female connectors (6 connections): 2/step counter, 2/battery 12V, 2/tubular motor
 - 1 male connector (5 connections): for connection with the regulator
- [See: Versions of Manual Control Circuits in the motor. Page 7](#)
[See: Cable specifications. Page 8](#)
- 5-wire cable sleeve 4m long with female connectors for connection with the regulator

INSTALLATION

Where to install the motor

The engine is always to be placed on the outside surface of the building. Depending on the installed air inlet system, it is to be fixed on a smooth and firm wall or surface.

How to fix the motor to the surface

The fixing side of the lifting motor must contact the anchoring area over its entire surface. This will avoid any type of deformation of the chassis, guaranteeing a correct functioning of the equipment.



As the motor is always to be fixed outdoors, it must be not placed on a slurry outlet or below the roof drain. If there are no other solutions, it must be protected as much as possible (with an awning, for example)

The chassis is provided with 4 fixing holes on the rear side.
The fixing is to be done with screws and suitable plugs (not included).

Distance between the fixing holes

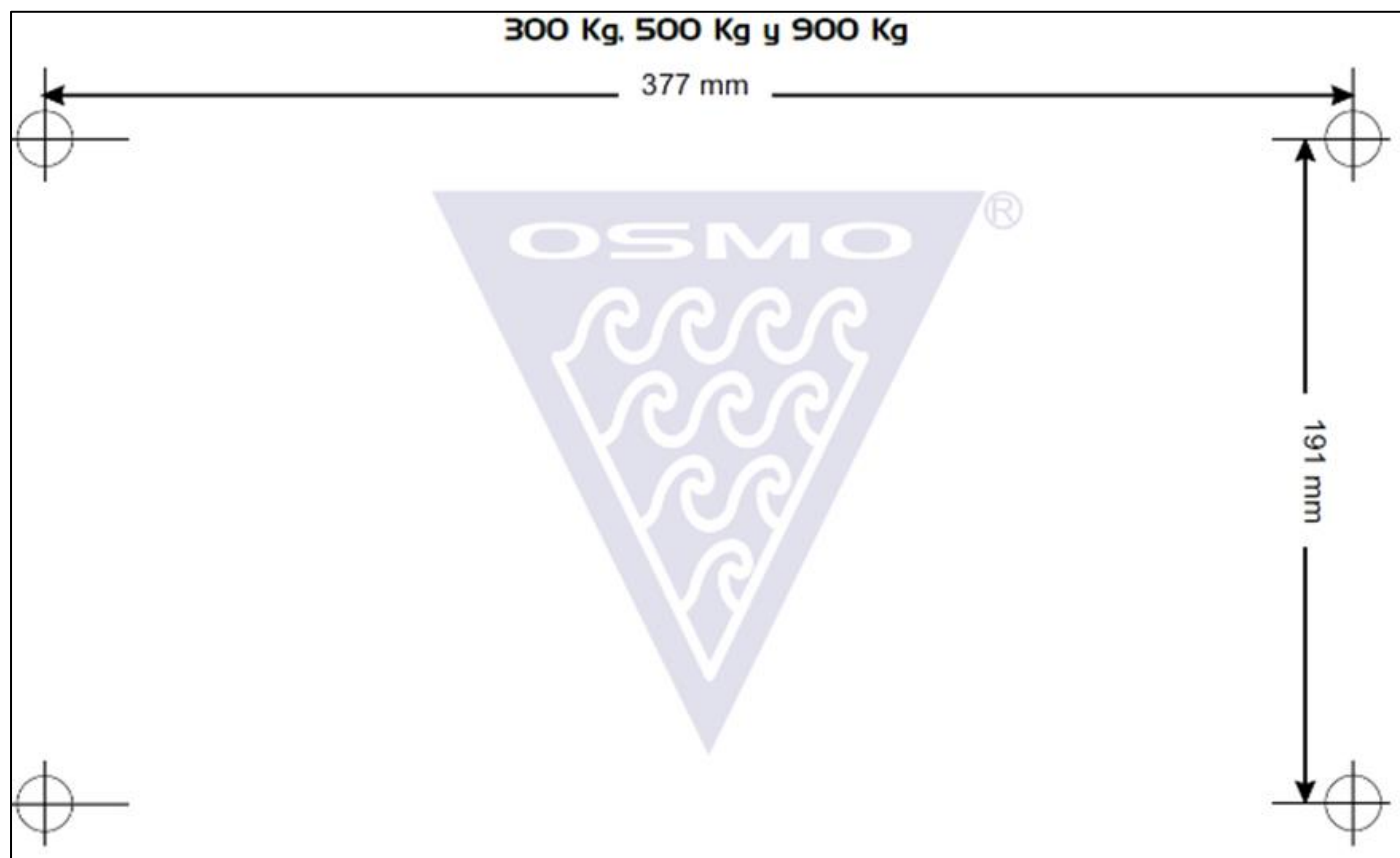

INSTALLATION

How to adjust the lifting system with tubes

- **Fix the towline to the tube, fastening it with an appropriate flange.**
- **IMPORTANT: Turn the towline around the tube twice, to avoid direct pulling from the fixed point.**
- **Proceed to connect the towline with the installed air inlet system according to the building characteristics.**

Installation scheme with the air inlets

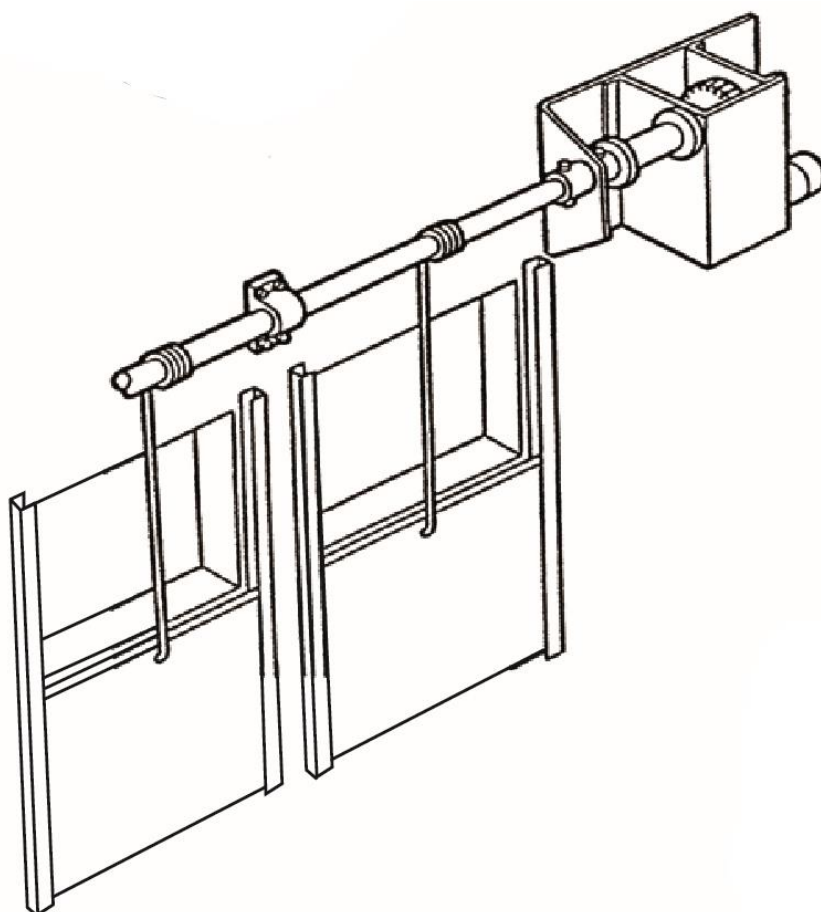

See: Recommendations for towline. Page 7

See: Recommendations for tube system installation. Page 6

INSTALLATION

Recommendations for tube system installation

Dimensions of the motor shaft



**The motor shaft diameter is 20mm.
It is adaptable for tubes with bigger diameters,
completing the fitting with appropriate inner bushes (not included)**

Distance between the support brackets and the tube joining

Recommended, optimal: 4 support brackets per standard tube 6m each.

Distance between the support brackets: 1.5m.

Distance between the tube joining / fixing to the motor: 0.75m from the next support bracket to the joining end.

Fig. Recommended optimal installation scheme with 4 support brackets for tubes 6m/each.

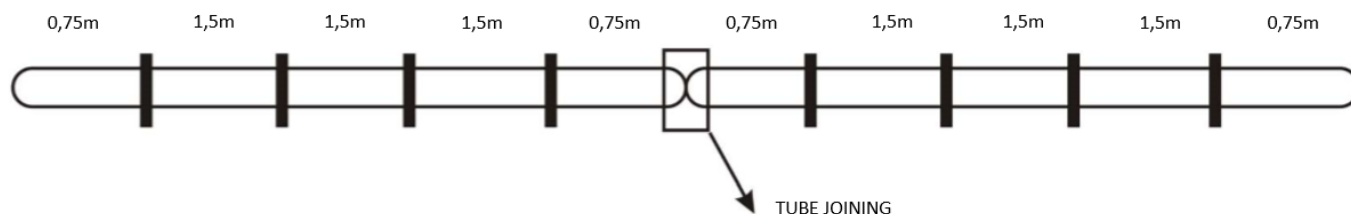

Recommendable minimum: 3 support brackets per standard tube 6m each.

Distance between the support brackets: 2m.

Connection of the tubes / fixing to the motor: 1m from the next support bracket to the joining end.

Fig. Recommended minimum installation scheme with 3 support brackets for tubes 6m/each.

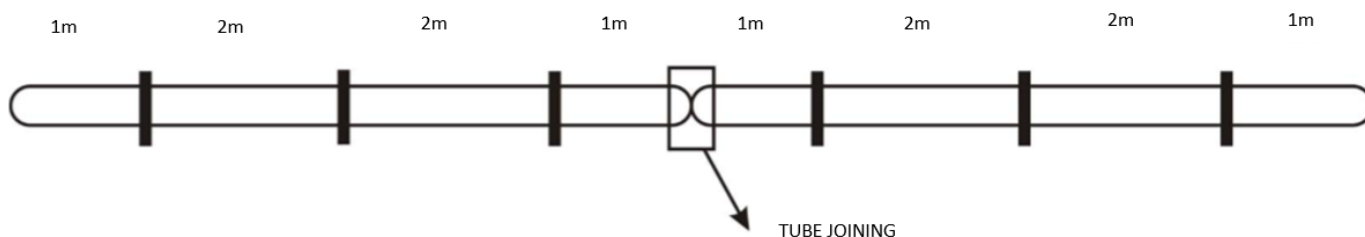

INSTALLATION

Recommendations for towlines

Suitable towline type

**OSMOEUROPA does not provide fastening elements between the motor and the air inlets, such as towline, tubes, etc.
However, we can give some advice**

The towline with optimal thickness and flexibility tends to be damaged less during winding. The flexibility of a towline depends on the number of the metal wires. The more threads it has, the more flexible it is.



Towline maintenance



- Do not grease the towline, since it accumulates dust forming mud and hindering its correct operation.
- It is advisable to clean dirt off the air inlets and the lifting system on a regular basis
- Dirt increases the load on the fastening elements and motors and can cause their anticipated wear.

CONNECTION

How to connect the motor to the regulator

This motor is designed for operation with OSMO regulators.

Inside of each motor, there is a Manual Control Circuit with the Input to connect the corresponding Regulator. This Input is located next to the Pushbuttons on the Manual Control Circuit inside the motor. See Fig.1

Fig.1

Versions of the Manual Control Circuits in the motor

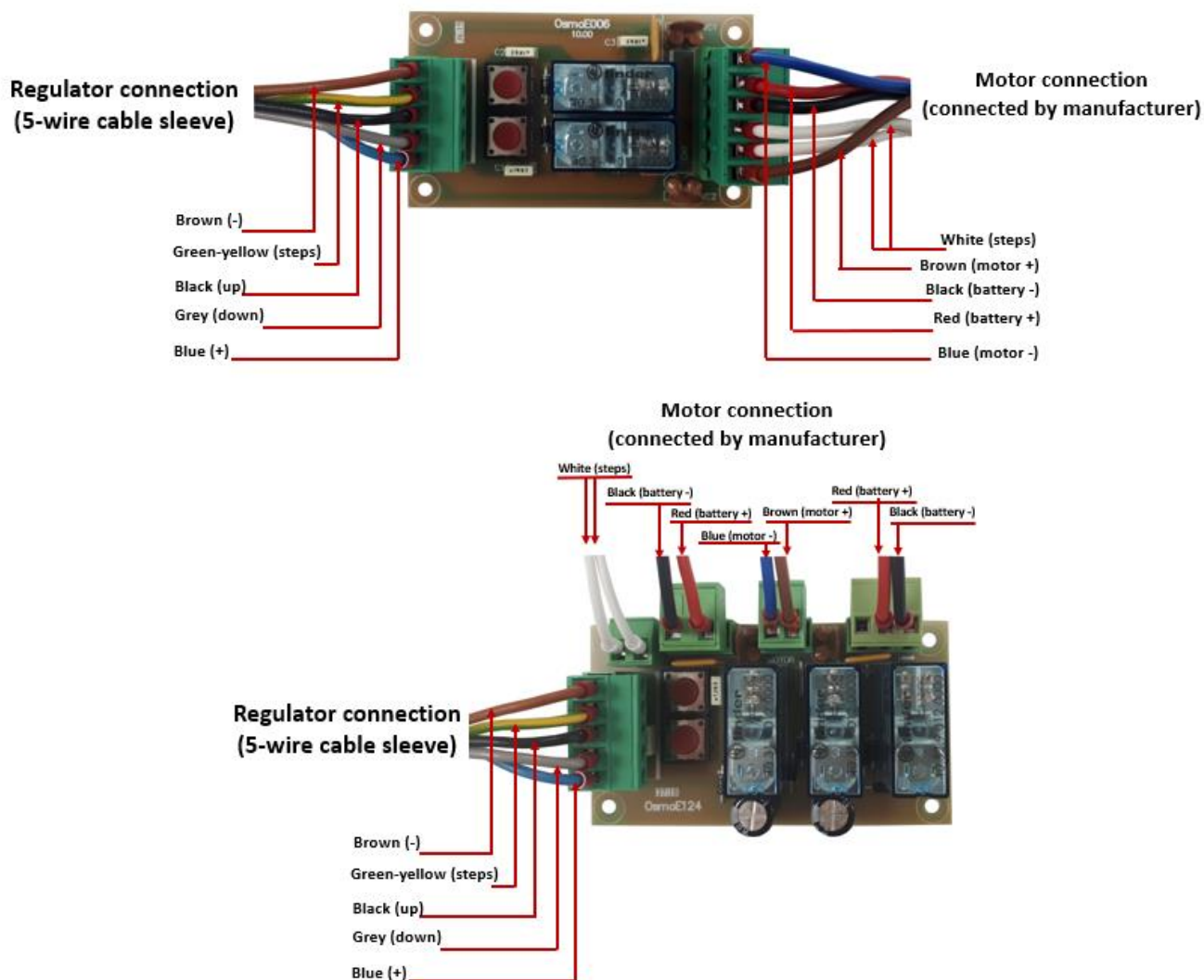

IMPORTANT

- **BEFORE MAKING ANY CONNECTION** between the regulator and the motor, make sure of the correct position of the cables in the connectors. See fig. 1. Because any inversion of voltages in 12V or 24V will cause a malfunction of the equipment and even the breakage of the electronic board, microchip, etc.
 - **IF IT IS NECESSARY TO CHANGE** the 5-wire cable sleeve, do not connect it to any terminal until installation has been completed and the connector on both ends are put.

CONNECTION

Cable specifications

OSMOEUROPA provides a cable sleeve for connection between the motor and **OSMO** regulator

LENGTH	4m
WIRES	5
THICKNESS / 1 WIRE	1mm

Regulator connection (5-wire cable sleeve)

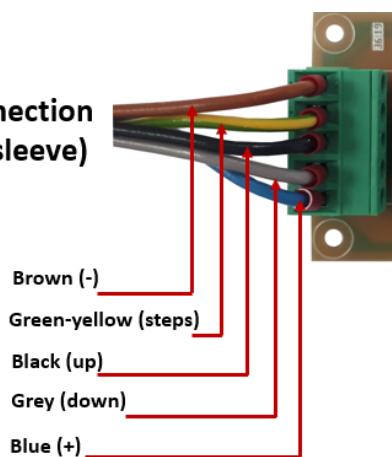

How to prolong the connecting cables



The cable change must be done by an electrician authorized for electrical installations of this type.

The cable sleeves used by **OSMOEUROPA** are standardized and can be purchased from your usual supplier of electrical equipment of the necessary length as long as they meet the specifications indicated above.



Safety warnings for cables

- IN NO CASE pass the motor cable sleeve through the same tubes with other cable sleeves of 230V/400V.
- IN NO CASE pass the cable sleeve near heating sources
- IT IS COMPULSORY to use the cable sleeve and NOT loose cables.
- AVOID prolonging the cable sleeve by means of connecting different cables with each other. The joining points are at risk of moisture or dirt entering, which causes equipment breakdown. If such connection is unavoidable, take measures to keep the joining points isolated from the environment and between each other.
- IF IT IS NECESSARY TO CHANGE the 5-wire cable sleeve, do not connect to any terminal until its installation is finished and the connector are properly joined on both ends.

BEFORE PROGRAMMING

Remember to connect the Motor-Battery connector

OSMO motors leave the factory with the batteries disconnected to avoid discharging them.

See Fig.1

Battery connectors disconnected

Fig.1

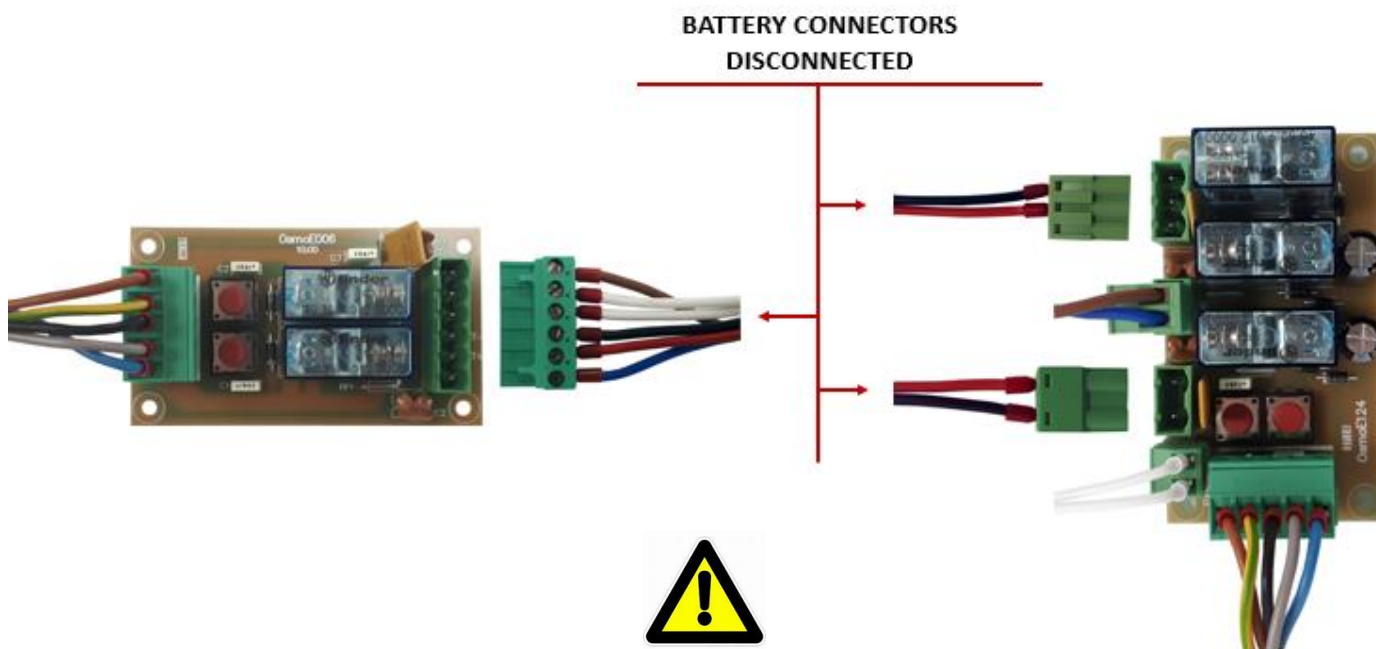

Antes de proceder a la programación del recorrido inicial de las ventanas, asegurarse de la correcta posición de los cables y las conexiones en el motor y el regulador

Before programming the complete limit switch, make sure the correct position of the cables and connections in the motor and the regulator

[See: How to connect the motor to the regulator. Page 7](#)

[See: Cable specifications. Page 8](#)

**AND THE LAST STEP PRIOR TO PROGRAMMING:
connect the Battery connectors
to the connectors on the corresponding Motor Circuit.**

SAFETY MEASURES IN CASE OF FAULTS

Any blockage of the motor will be reflected on the display of OSMO regulator or controller connected to the equipment.

Go to the regulator to see the breakdown indications and find the solutions in its instruction manual.

How to use the Manual Control Circuit inside the motor

Inside each motor, there is a Manual Control Circuit with Up/Down Pushbuttons, which are able to move the motor independently from the whole system.

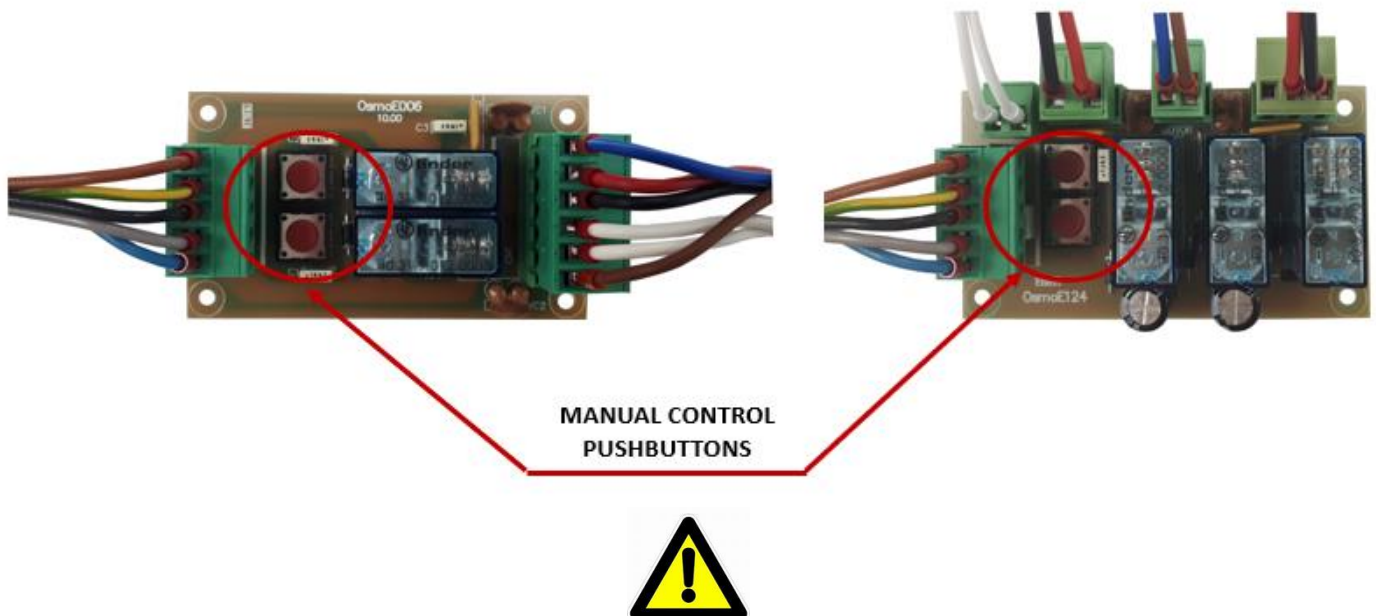

IMPORTANT: Manual Control Circuit is ONLY used when the regulator breakdown blocks the functioning system and we cannot solve the problem temporarily.

REPROGRAMAR el regulador DESPUÉS DE HABER UTILIZADO los pulsadores Control Manual, estableciendo nuevamente los finales de carrera (límites del recorrido máximo y mínimo). Keep in mind that, after having used the buttons on the motor manual circuit, the regulator will not know the current position of the air inlets and may order to open or close excessively, causing a serious fault.

DO NOT USE the Manual Control Circuit for moving the lifting motor while the regulator is in order. If you do it, the number of centimetres of the towline that the lifting motor has rolled up will be varied, and the regulator will not be able to detect them, resulting in a mismatch of the lifting motor movements.

SAFETY MEASURES IN CASE OF FAULTS

Any motor blockage or fault will be reflected on the display of the OSMO controller or regulator connected to the equipment.

Refer to the regulator instruction manual to see the indications of faults and solutions.

Mechanical limit switch

Guarantee of protection of the air inlets from breaking, in case of short circuit or abnormal operation

OSMO regulators that give orders to the motors are provided with an electronic limit switch programmed to set the opening and closing limits.

IN ORDER TO PROVIDE WITH GREATER SECURITY to the equipment and the installation, **OSMO** motor is provided with an integrated mechanical limit switch to avoid possible breakage of the air inlets or towlines due to malfunctions caused by reasons external to the equipment (broken cables, bad connections, storms etc.)

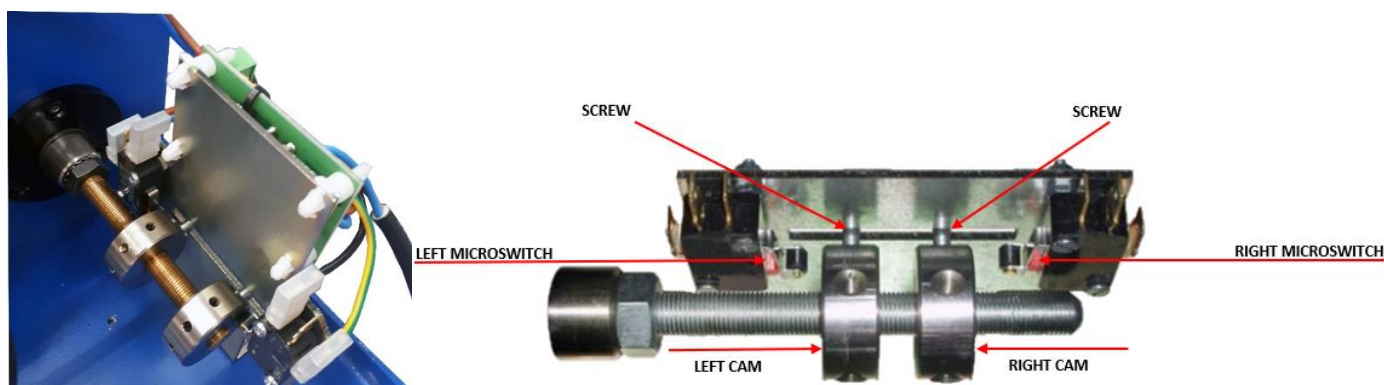

THE ADJUSTMENT OF THE MECHANICAL LIMIT SWITCHES ARE MADE at the same time as the programming of the electronic limit switches in order to synchronize the route of the air inlets.

See: [The regulator instruction manual for the motor.](#)

IN NO CASE manipulate and / or remove the mechanical limit switch or its components. It can cause distortion of the electronic program and impede assured operation.

References of the mechanical limit switches according to the motor type

REFERENCE	MOTOR KG	FIXING SYSTEM
4M00520	300	1 SHAFT FOR PULLEY OR TUBE
4M00525	500	1 SHAFT FOR PULLEY OR TUBE
4M00527	500	2 SHAFTS FOR PULLEY OR TUBE
4M00528	900	2 SHAFTS FOR PULLEY OR TUBE
4M00529	900	1 SHAFT FOR PULLEY OR TUBE

BUILT-IN BATTERIES

Specifications



The general characteristics of **OSMOEUROPA** energy storage systems composed of rechargeable lead-acid batteries are as follows:

- Construction using lead plates and lead dioxide.
- The diluted electrolyte is sulfuric acid, absorbed by separators, and therefore immobilized.
- It has special valves that do not allow the release of hydrogen and oxygen gases, thus avoiding excessive accumulation and increased pressure in an accidental overload.
- AGM Technology (Absorbent Glass Mat):
- Efficient recombination of gases.
- Not restricted for air transport: complies with special provision A67 (IATA / ICAO).
- Fully sealed battery.
- Maintenance free of adding electrolyte or water.
- It can be mounted in any orientation.
- Long service life in floating or cyclic applications.
- Low self-discharge.

	1270	1245	
Nominal Voltage	12	12	V
Nominal Capacity	7.0	4.5	Ah
Length	151	90	mm
Width	65	70	mm
Height	94	101	mm
TOTAL length	100	107	mm
Weight	1.95	1.47	kg

BUILT-IN BATTERIES

Maintenance

If the batteries do not have adequate charging, it is very possible that the regulator begins to display the indicators of the motor failure (blocking, loss of step counting etc.)

The average service life of a battery is 2 years, as long as its maintenance has been adequate.

Check the internal battery of the lifting motor annually to ensure proper operation.

How to check the motor's batteries

- Have the air inlets completely closed
 - Disconnect the regulator from the power source - 230V mains, generator set or solar panel.
 - Change its operation to MANUAL mode
 - By pressing the UP / DOWN buttons on the regulator, open and close the air inlets completely 1 time.
 - **IF THE PROCESS OF OPENING AND CLOSING THE AIR INLETS HAS BEEN FLUID AND THE MOTOR HAS NOT PRESENTED SIGNS OF POWER LOSS, *THE MOTOR'S BATTERIES ARE IN RIGHT CONDITION.***
 - Connect the regulator to the power source again.
 - Change its operation to AUTOMATIC MODE
- IT IS NOT NECESSARY REPROGRAM IT AGAIN**

- **SI EL PROCESO DE ABRIR Y CERRAR LAS VENTANAS HA SIDO INTERRUMPIDO Y EL MOTOR HA PRESENTADO SIGNOS DE PERDIDA DE POTENCIA, **LAS BATERÍAS DEL MOTOR NECESITAN CAMBIO** y the corresponding OSMO regulator connected to the motor will show the fault indications.**

[See: Instruction Manual of the corresponding OSMO regulator. .](#)

- Change the batteries in the motor.
- Connect the regulator to the power source again.

RESET THE REGULATOR AND REPROGRAM THE LIMIT SWITCHES AGAIN

[See: Instruction Manual of the corresponding OSMO regulator. .](#)

BUILT-IN BATTERIES

Correct battery maintenance in facilities WITH 230V

- **NEVER turn off the regulator connected to the motor.** If it is not used temporarily (for example, during the cleaning of the farm), it must be left in the MANUAL mode. The regulator consumes very little electricity, but if you turn it off completely it will stop charging the batteries and they will drain.
 - If the facility is not going to be used for a long time and there is no other choice but to disconnect the regulator, make sure to disconnect the battery connectors from the Manual Control Circuit in the motor. For it:
 - Open the motor's chassis to access the Manual Control Circuit
 - Disconnect the Battery connectors. See. Fig 1.

How to disconnect the batteries from the motor

Fig.1

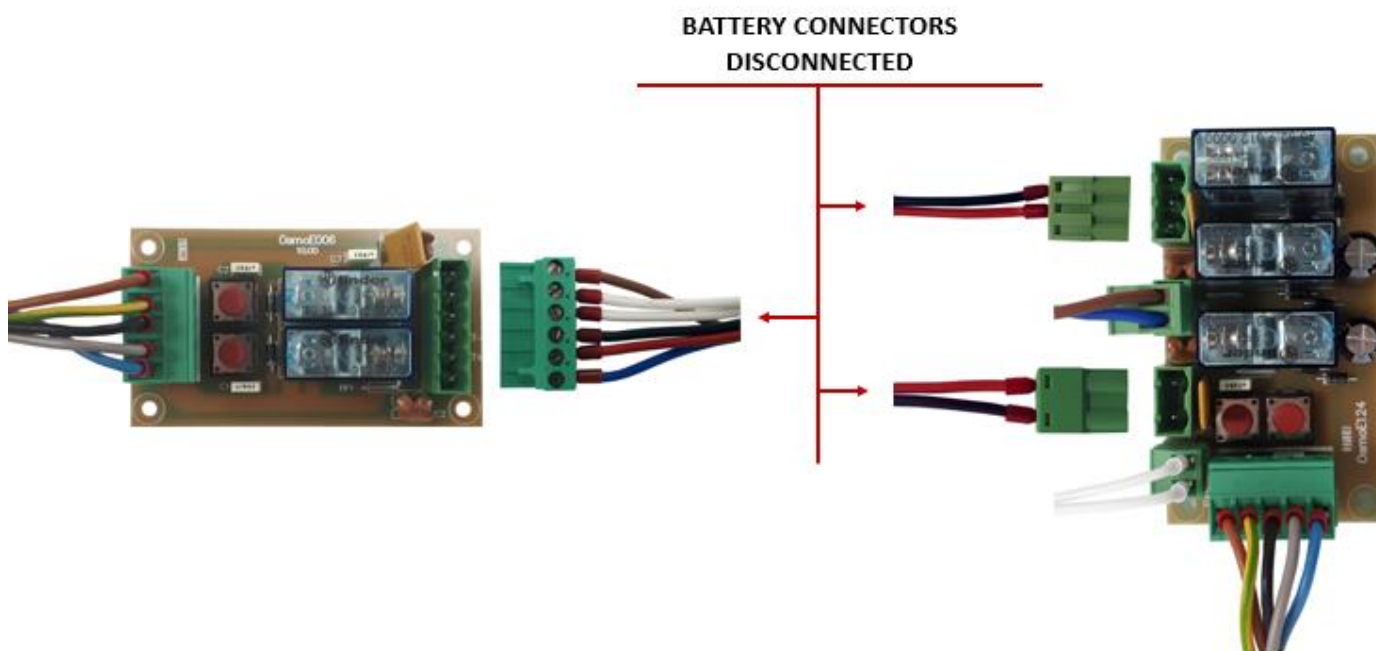

For battery maintenance WITHOUT 230V:
See: Instruction Manual for **OSMO** DC-DC Converter.