



## OSMO SYSTEM FOR VENTILATION CONTROL

### SAVING IN ELECTRICITY



#### POWER SUPPLY UNIT OFA 12 V

REF. 4C51013



#### DESCRIPTION:

The OFA power supply supplied at 230 V is the essential component for mechanical ventilation that supplies power to OSMO lifting motors for their operation in continuous movement according to 0-10 V signals. At the same time, it charges the lifting motor batteries\* so that they can come into operation in the event of any power supply cut. Complies with IP56 protection standard.

\* 12 V batteries of OSMO lifting motors allow to automate farms WITH 230 V power supply, providing an autonomy of up to 24 hours in case of power supply cut

#### TECHNICAL SPECIFICATION:

230 V / 12 V, 50 Hz

Dimensions (length x width x height): 200 x 80 x 150 mm

Weight: 761 gr

Included : 5-wire flexible multi-conductor connecting sheath, L 50 cm

Connection to 12V lifting motors

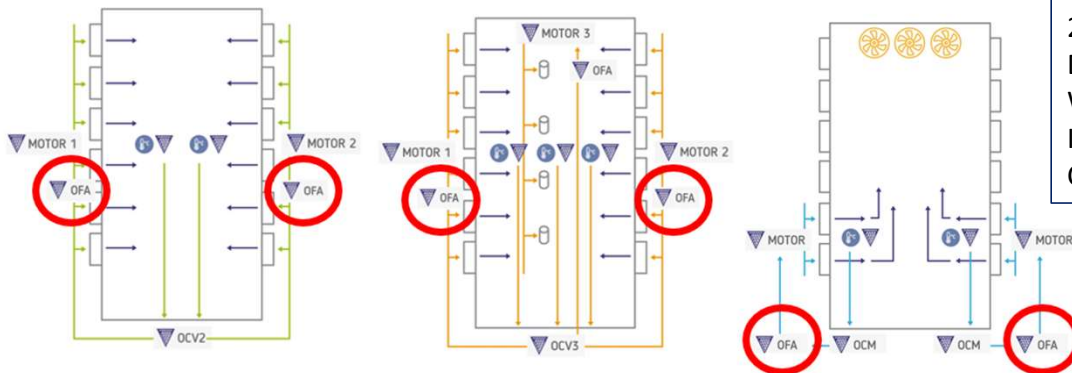

CONSULT OSMO MOTORS, REGULATORS AND ACCESSORIES TO COMPLETE THE VENTILATION SYSTEM